

Vol. 1

OPEN

YOUR



OWN

WORLD



**Glassco** is one of the leading name in Architectural Glass Solutions, offers large number of product range, Now also provides you advanced fabrication solutions, to enhance the Beauty of homes & provides more secure and elegant solutions for it.

We have safer, stronger, durable & attractive product line of German, Greek, Indian & Turkish technology with quality & technological advancement in UPVC & Aluminum solutions, like, UPVC & System aluminum's doors, heavy partitioning systems, Sliding & Casement windows, French windows, Domal series, Top hung & Ventilation systems & many more... to fulfill all related needs & making the life more transparent like glass of our great customers, who are our strength and inspire us to do Better day by day to move forward. It started from the concept as an initiative of creative minds to the renowned company today,

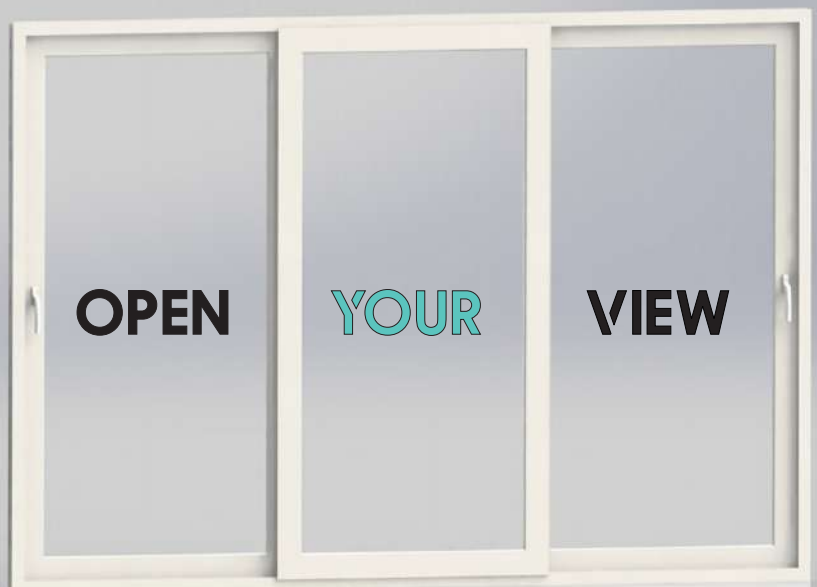

<b>Fenster Typologies (Types of Windows)</b>	<b>04</b>
<b>UPVC Systems</b>	<b>05 (05-12)</b>
I-60 Sliding Series	06
I-75 Sliding Series	07
I-64 Sliding Series	08
I-50 Sliding Series	09
I-44 Sliding Series	10
I-60 Casement Series	11
I-39 Casement Series	12
<b>Advance Aluminum Series Systems</b>	<b>13 (13-18)</b>
A-28 Mini Slim Series	14
A-38 Mini Slim Series	15
A-3500 Series	16
A-3000 Series	17
A-4000 Series	18
<b>Premium Aluminum Series Systems</b>	<b>19 (19-25)</b>
SMARTIA M14600 Series	20
SMARTIA M45000 Series	21
COMFORT M900 Series	22
COMFORT M940 Series	23
SMARTIA M9800 Series	24
SUPREME S650 PHOS Series	25
<b>Aluminum Domal Section Series</b>	<b>26</b>

## Sliding Systems

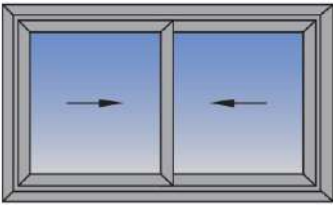

1). Double Horizontal sliding sash

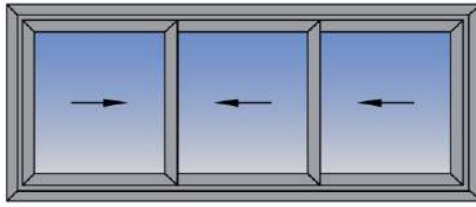

2). Triple Horizontal sliding sash

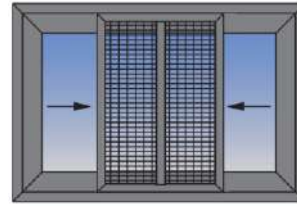

3). Double Horizontal sliding sash with fly net

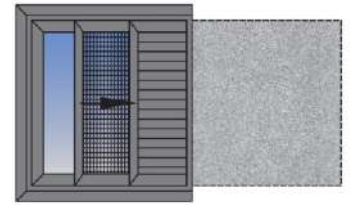

4). Single Pocket sash with fly net & shutter

Available in These series

UPVC Systems



I-60, I-50, I-64,  
I-75, I-44 Series

Advance Aluminum Systems

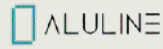

A3000, A3500, A28,  
A38 Series

Premium Aluminum Systems



M12500, M14600, M45000,  
M900, S650 PHOS Series

Domal Aluminum Systems



GDJ-10 Series

## Sliding Systems

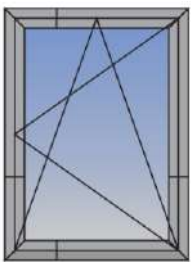

1). Single Tilt & Turn Casement

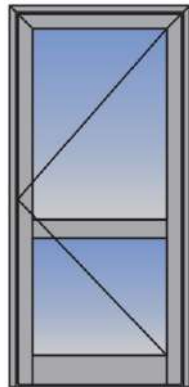

2). Door Casement

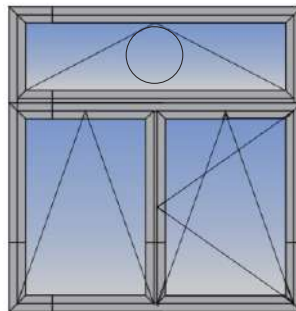

3). Tilt & Turn with Side-hung Casement (Ventilation)

Available in These series

UPVC Systems



I-60 & I-39  
CASEMENT Series

Adv. Alu. Sys.

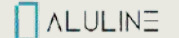

A4000 Series

Prem. Alu. Sys.



M940 Series

Prem. Alu. Sys.



GDJ-20 Series

## Sliding Folding Systems

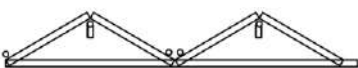
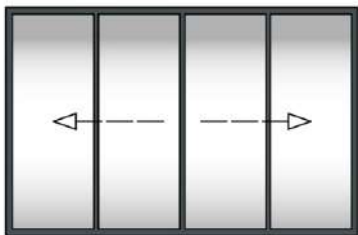

Sliding Folding System

Available in These series

UPVC Systems



I-60 Series

Prem. Alu. Sys.



M9800 Series

## Corner Sliding Systems

Corner Sliding System

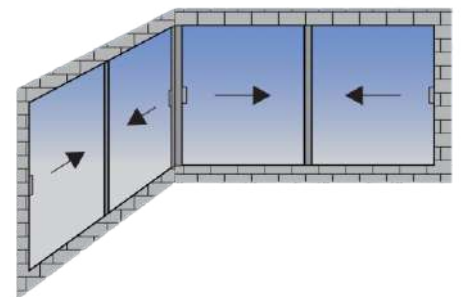

Available in

UPVC Systems



I-60, I-75 Series

Prem. Alu. Sys.



S650 PHOS Series

# UPVC Systems

Powered By,

**VEKA**

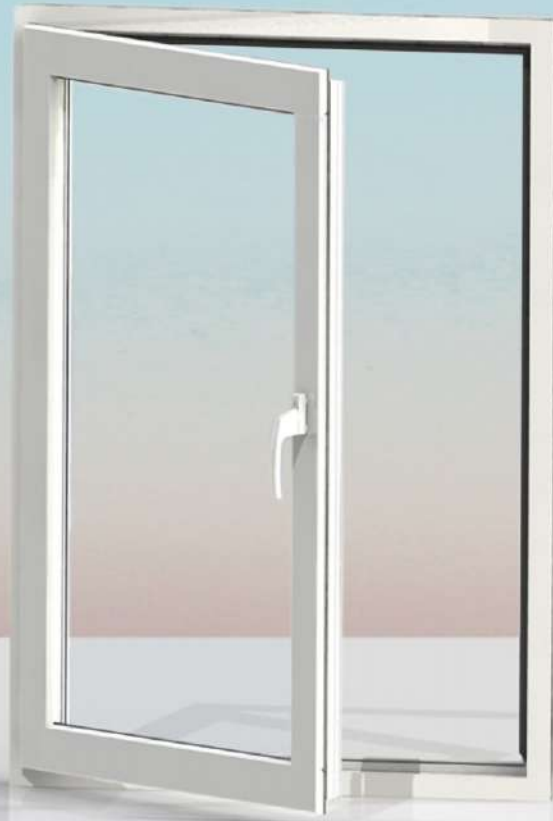

**Glassco** provides you the uPVC windows of NCL Veka & uPVC windows designed to make your place more beautiful and elegant with the qualities of sound insulation, wind resistance, durability & simplicity. sash slides into the frame with a soft motion, making the uPVC smart-slide window so simple to use that it is virtually impossible to operate it incorrectly.



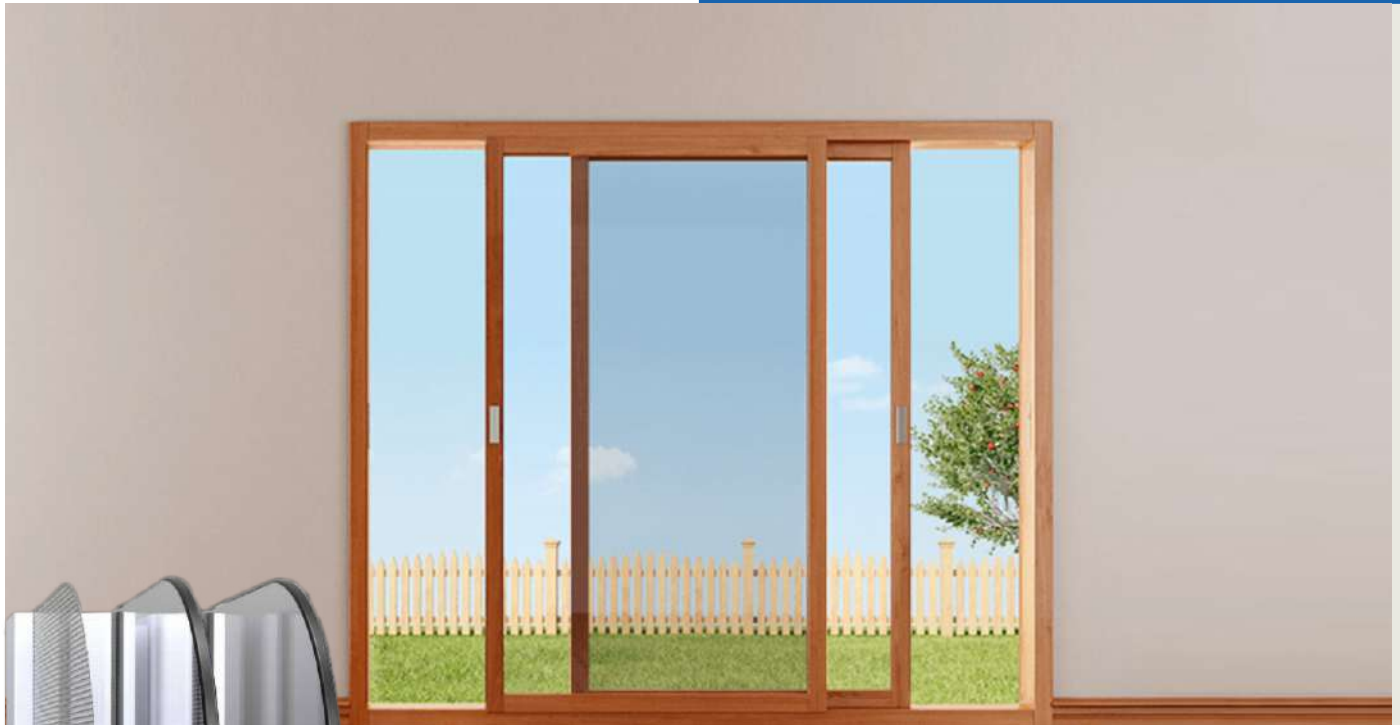

## VEKA I - 60 SLIDING

### TECHNICAL DETAILS

- Shutter Size ▶ 58mm, 65mm, 75mm, 90mm
- Track Type ▶ 2T, 2.5T, 3T
- Glazing ▶ 5mm to 24mm
- Rail Track Material ▶ Aluminum
- Joint Angle ▶ 45°
- Max. Size ▶ 8ft x 8ft

### FEATURES

- Easy to use
- Cost efficient
- Multiple size options
- Aesthetically pleasing
- Maintenance free
- Provides 50% opening at any given point

### LAMINATION SHADES

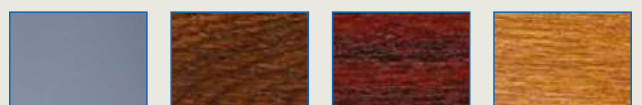

VEKA's I-60 Sliding system is evergreen and very suitable for regular home windows. The entire system is based on the elevation depth. This means that it can be combined with standard hardware available on the market. This series comes with option of sliding door and windows and can be used at multiple construction sizes.



Veka I-75 sliding series is one of the best premium series. A durable product that can be your home partner for long life. More heavy & strong, also used in sliding door. Available in various options to customize as you need.

## VEKA I - 75 SLIDING



### TECHNICAL DETAILS

- Shutter Size ◀▶ 82mm, 100mm
- Track Type ◀▶ 2T, 3T
- Glazing ◀▶ 5mm to 24mm
- Rail Track Material ◀▶ Aluminum
- Joint Angle ◀▶ 45°
- Max. Height ◀▶ 15ft x 15ft

### FEATURES

- Easy to use
- Multiple size options
- More durable & also suitable for Doors
- Aesthetically pleasing
- Maintenance free
- Provides 50% opening at any given point

### LAMINATION SHADES



Veka I-64 sliding series can enhance the architecture of the house with the good quality build. This series comes with various options to select best suitable for you.



## TECHNICAL DETAILS

- Shutter Size ▶ 60mm, 76mm, 90mm
- Track Type ▶ 2T, 2.5T, 3T
- Glazing ▶ 5mm to 12 mm
- Rail Track Material ▶ Aluminum
- Joint Angle ▶ 45°
- Max. Size ▶ 12ft x 12ft

## FEATURES

- Easy to use
- Cost efficient
- Multiple size options
- Aesthetically pleasing
- Maintenance free
- Provides 50% opening at any given point

## VEKA I - 64 SLIDING

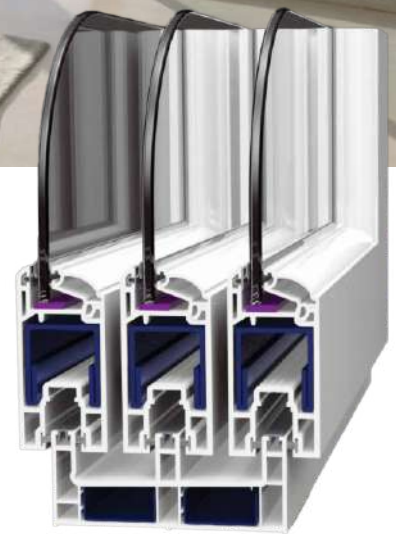

## LAMINATION SHADES



Veka I-50 is slim series is more affordable and it slides into the frame with a soft motion & in better movement best choice for small & medium size windows.

## TECHNICAL DETAILS

- Shutter Size ▶ 60mm, 76mm, 90mm
- Track Type ▶ 2T , 2.5T, 3T
- Glazing ▶ 5mm to 12 mm
- Rail Track Material ▶ Aluminum
- Joint Angle ▶ 45°
- Max. Size ▶ 5ft x 5ft

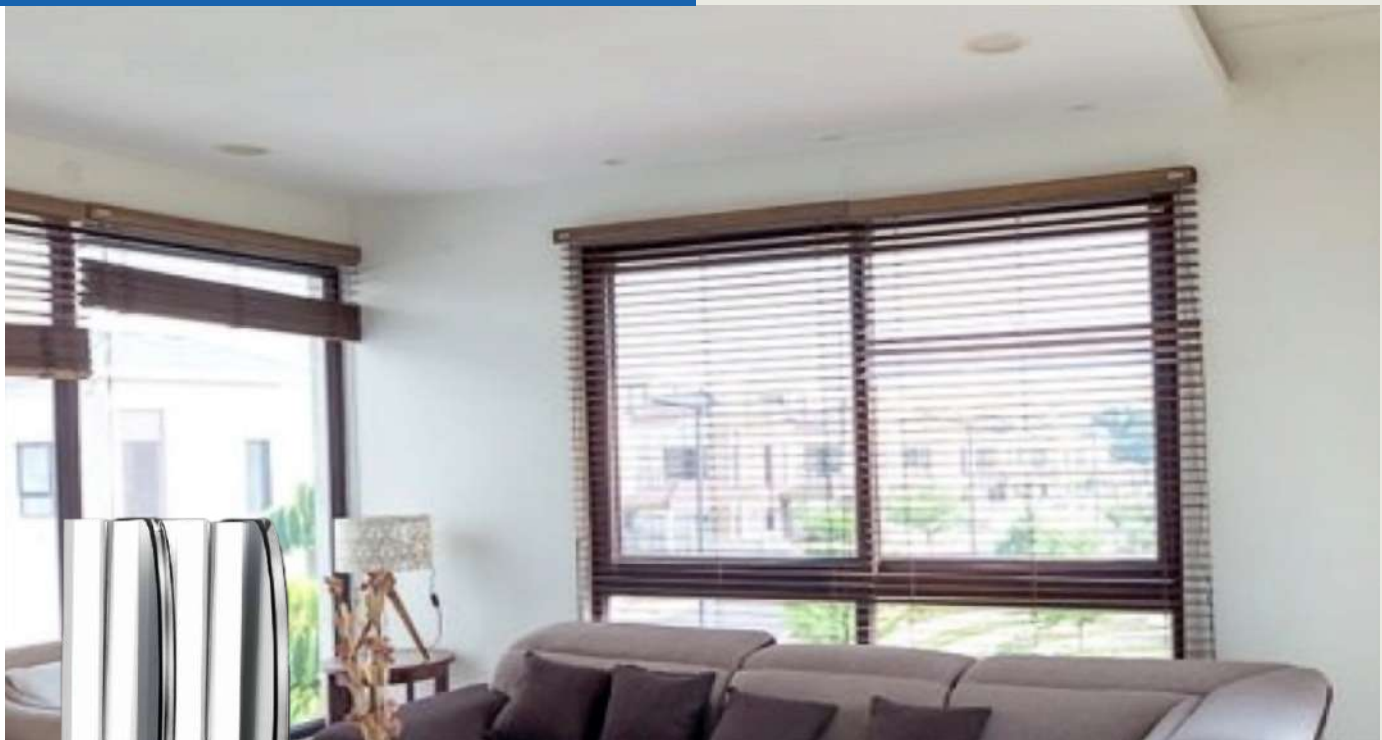

## VEKA I - 50 SLIDING

### LAMINATION SHADES



## FEATURES

- Easy to use
- Cost efficient
- Multiple size options
- Aesthetically pleasing
- Maintenance free
- Provides 50% opening at any given point
- Metal Reinforcement for Support

## TECHNICAL DETAILS

- Shutter Size ▶ 60mm, 76mm, 90mm
- Track Type ▶ 2T , 2.5T, 3T
- Glazing ▶ 5mm to 12 mm
- Rail Track Material ▶ Aluminum
- Joint Angle ▶ 45°
- Max. Size ▶ 4ft x 4ft

## LAMINATION SHADES



Veka I-44 series is specially designed for vantilation and small size windows making it best for small sized fabrication works.



## FEATURES

- Easy to use
- Cost efficient
- Multiple size options
- Aesthetically pleasing
- Maintenance free
- Provides 50% opening at any given point
- Dynamic design for Support

**VEKA**  
I - 44  
SLIDING

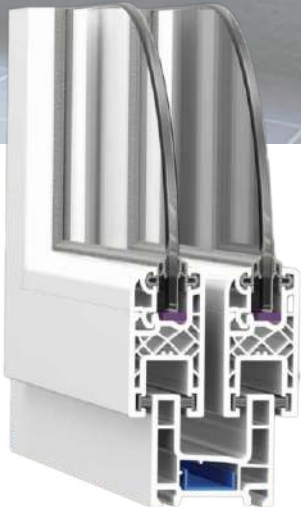

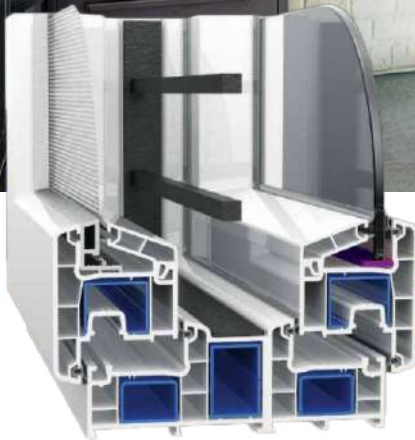

## VEKA I - 60 CASEMENT

Veka I-60 casement series is one of the best strongest and durable profile to build a big size to small size windows and doors. Reduces the noise and give you the low sound environment.

### TECHNICAL DETAILS

- Frame profile ▶ 39mm,75mm
- Shutter Size ▶ 75mm,55mm
- Door sash ▶ 102mm
- Glazing ▶ Aluminum
- Mullion ▶ 74
- Joint Angle ▶ 45°
- Max. Size ▶ 7ft x 7ft

### LAMINATION SHADES

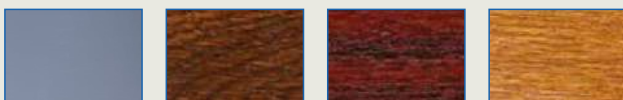

### FEATURES

- Eases cleaning for the outside surface of glass.
- Allows more air to enter
- barrier against dust and pollution
- Double sealing with TPV gaskets for enhanced thermal and sound insulation.
- Easy to use & Cost efficient
- Offers an unobstructed view.
- Multiple size options
- Aesthetically pleasing & Less Maintainance

## FEATURES

- Eases cleaning for the outside surface of glass.
- Allows more air to enter
- Barrier against dust and pollution
- Double sealing with TPV gaskets for enhanced thermal and sound insulation.
- Easy to use & cost efficient
- Offers an unobstructed view.
- Multiple size options
- Aesthetically pleasing & Less Maintenance

## TECHNICAL DETAILS

- Frame profile ▶ 39mm,75mm
- Shutter Size ▶ 75mm,55mm
- Door sash ▶ 102mm
- Glazing ▶ Aluminum
- Mullion ▶ 74
- Joint Angle ▶ 45°
- Max. Size ▶ 7ft x 7ft

Veka I-39 casement series is made for the openable and fix windows that can provide a best architectural view to your elevation. Made with the best materials to give you long life strength. Best suitable for ventilation



**VEKA**  
I - 39  
CASEMENT

## LAMINATION SHADES



# Advanced Aluminum Systems

Powered By,

 ALULINE



**Glassco** advanced aluminum series by Aluline is one of the best choice for anyone, It designed to provide increased efficiency and accuracy resulting in a high-quality end product, more Durable, slim, attractive & functional then regular aluminum windows, making it advanced system windows.



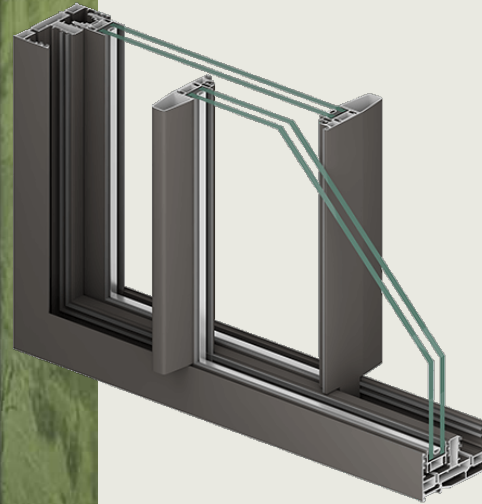

**ALULINE**

**A-28 MINI SLIM SERIES**

## TECHNICAL CHARACTERISTICS

Visible aluminium face width	28mm
Frame height	52mm
Frame width	112mm/174mm
Sash height	28.5mm
Sash width	35mm
Interlocking profile width	18mm / 30mm
Roller weight capacity	300kg
Glazing	28mm
Shades & Colors	100+ shade customization

This remarkable series is developed keeping in mind the requirements of builders / developers and architects who need the most advanced Minimal systems at budgeted rates. This system can adapt to both, windows and doors. The robust design can deliver truly marvellous windows to the project and enhance the elevations to a very great extent. Large panels can be made in this system and effortless sliding can be expected since the trolleys are designed, manufactured and sourced from one of the finest companies in the world. The fabrication and assembly details have been well thought of so as to give the lowest effort that any Minimal system can offer.

# A-38 MINI SLIM SERIES

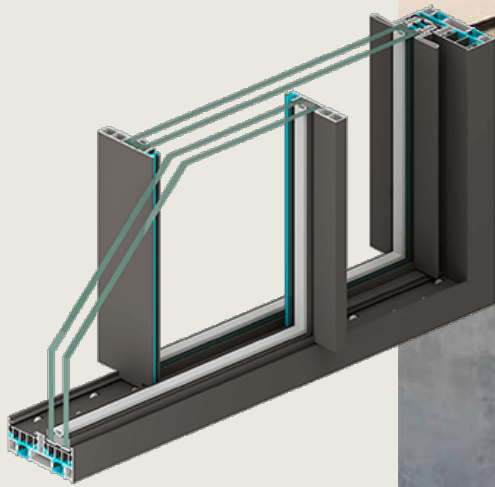

ALULINE

## A-38 MINI SLIM SERIES



In this exquisite 'floor to ceiling series' the aluminum window have been significantly reduced & have been crafted in a minimal design to lessen the number of visible frames and sash. This maximizes the spans and openings of rooms to light and landscape and the windows transform into a large panoramic view. A38 Mini slim series offers double glazing as standard making this a system which is a culmination of modern design concept, ensuring maximum transparency and excellent performance using the latest and most advanced technology. This series made from high-performance aluminum and it can endure heavy wind loads & ensures safety even when subjected to severe weather conditions.

### TECHNICAL CHARACTERISTICS

Visible aluminium face width	20mm
Frame height	50mm
Frame width	125mm
Sash height	45mm / 19mm
Sash width	43mm
Interlocking profile width	20mm
Roller weight capacity	400kg
Glazing	38mm
Shades & Colors	100+ shade customization

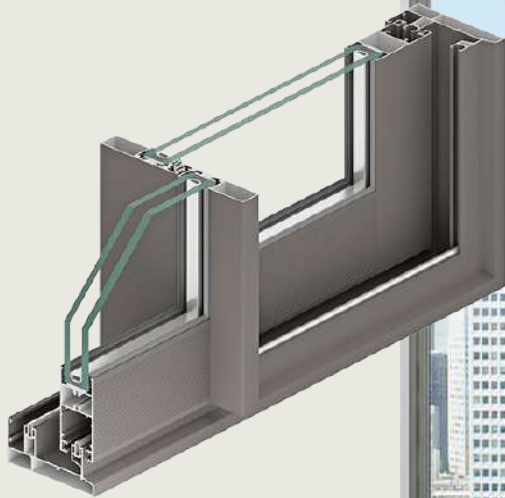

**ALULINE**  
**A-3500 SERIES**



This marvelously designed slim series is the ideal solution for sliding doors which require aesthetic, performance & functionality. This series has been elaborated aiming to meet the highest standards in elegance, comfort, and performance. The interlocking profiles add a lot of glamour to the door system thanks to the slender form adapted in the design phase.

Its high wind resisting contrives makes it the ideal choice for sliding doors required for high rise residential buildings. If you love the elegant style of living, treat yourself with the excellent feature from this series.

## TECHNICAL CHARACTERISTICS

Visible aluminium face width	98mm
Frame height	39mm
Frame width	92mm / 142mm
Sash height	67mm / 75mm
Sash width	35mm
Interlocking profile width	20mm
Roller weight capacity	160kg
Glazing	6mm to 24mm
Shades & Colors	100+ shade customization

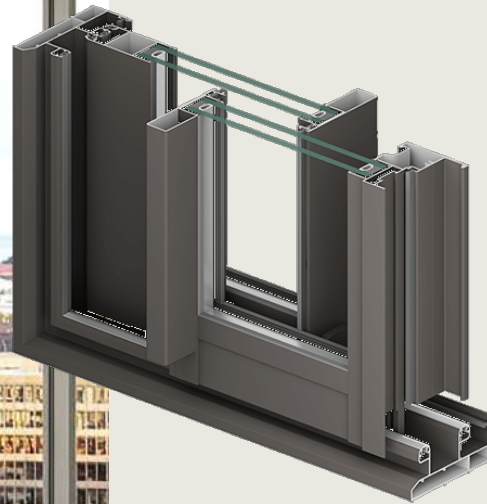

**ALULINE**  
**A-3000 SERIES**

### TECHNICAL CHARACTERISTICS

Visible aluminium face width	94mm
Frame height	39mm
Frame width	91mm / 136mm
Sash height	65mm / 57mm
Sash width	30mm
Interlocking profile width	20mm
Roller weight capacity	60-160kg
Glazing	23mm
Shades & Colors	100+ shade customization

Our A-3000 series is considered by many to be the best in terms of aesthetics, quality, durability and performance. However, what really sets this series apart is that it is probably the only slim line series in this segment. The versatility of this series is unmatched since it offers a wide range of locking solutions such as single point locking & multipoint flush locking. Keeping in line with the current requirement of the market wherein the Balconies are diminishing and windows are becoming an integral part of the elevation, this series is designed to merge with our fixed glass system at the bottom which doubles up as a railing thereby saving space and cost. This helps mostly when the window sill is not wide enough to cater to windows and railing separately.

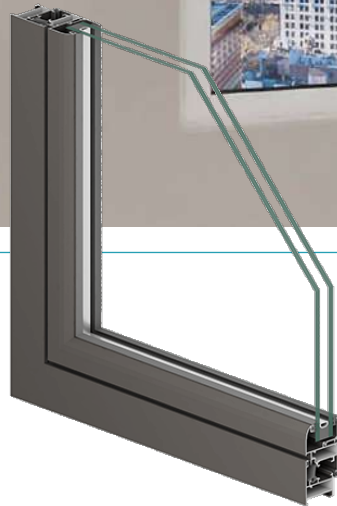

## ALULINE A-4000 SERIES

The A-4000 series offers all that you would expect, and more, from a budget casement window system. Specifically designed to be used in modern bathrooms, this series can also be used for small openings in bedrooms, common areas and other places which require 100% ventilation. This series' windows look excellent and also reduce noise and dust infiltration dramatically. It is a perfect option for commercial windows since it offers an unparalleled value for money.

### TECHNICAL CHARACTERISTICS

Visible aluminum face width	105mm/81mm
Frame depth	37mm
Sash width	87mm / 63mm
Mechanism Limitation	upto 80kg
Glazing	30mm
Shades & Colors	100+ shade customization

Powered By,



# Premium Aluminum Systems



**Glassco** premium aluminum series of Alumil is High range, premium quality & added value product, It built with durability and design both concept combined. Made in europe with an european standards stronger, slimmer, attractive and functional making it best choice in system windows.





### TECHNICAL CHARACTERISTICS

Visible aluminium face width	96.5 mm
Frame height	31.5 / 40 mm
Frame width	92 mm
Sash height	67 / 79 mm
Sash width	35 mm
Interlocking profile width	23 / 68.5 / 80.5 mm
Sash weight Up to	Up to 180 Kg
Glazing	8 up to 26 mm
Shades & Colors	100+ shade customization

Alumil SMARTIA M14600 is a non-insulated sliding system with slim lines. It meets the modern architectural trends and the requirements for especially high performance and is the ideal solution for sliding systems in warmer climates.

- / Basic system's depth 35 mm.
- / Maximum visibility and natural light with only 23 mm width at the interlocking profile.
- / Exceptional wind load resistance performance, certified under extreme conditions.
- / Easy access, with low threshold. Ideal for multi-track constructions.
- / Vast range of typologies, compatible with various mechanisms.
- / Smooth and easy gliding, thanks to inox rails.



Alumil SMARTIA M45000 is a flexible and robust non-insulated system for Lift & Slide and sliding doors. The system meets a wide range of needs with its modern flat design and exceptional performance, making it the ideal solution for large spans in warmer climates.

- / Basic system's depth 45 mm.
- / Maximum visibility and natural light with only 32 mm width at the interlocking profile.
- / Exceptional wind load resistance performance, certified under extreme conditions.
- / Flexible constructions of Lift & Slide and regular sliding doors with the same design.
- / Easy use of wide and heavy sashes thanks to the Lift & Slide mechanism.
- / Smooth and easy gliding thanks to inox rails.

### TECHNICAL CHARACTERISTICS

Visible aluminium face width	110.5 mm Lift & Slide 106 mm sliding
Frame height	40 mm
Frame width	113.5 mm
Sash height	80.5 mm Lift & Slide 76 mm sliding
Sash width	45 mm
Interlocking profile width	83 mm Lift & Slide 32 / 78.5 mm sliding
Sash weight Up to	Up to 300 Kg Lift & Slide Up to 180 Kg sliding
Glazing	21 up to 31 mm
Shades & Colors	100+ shade customization



## COMFORT M900 SERIES



### TECHNICAL CHARACTERISTICS

Visible aluminium face width	88 mm
Frame height	37.4 / 62.5 mm
Frame width	45 / 54.5 mm
Sash height	61 mm
Sash width	28 mm
Interlocking profile width	65.5 mm
Sash weight	Up to 80 Kg
Glazing	up to 20 mm
Shades & Colors	100+ shade customization

- / Sash Width 28mm.
  - / Supports Single or Double Glazing upto 20mm thickness
  - / Recommended for small to medium size spans.
  - / Easy access, with low threshold.
- Ideal for multi-track constructions.
- / Cooperates perfectly with the system COMFORT M940 for tilt & turn typologies.
  - / Smooth and easy sliding.

Alumil Comfort M900 is the lightest sliding for highly cost effective constructions. Ideal proposal for low cost solutions without compromising the quality.





## COMFORT M940 SERIES



### TECHNICAL CHARACTERISTICS

Visible aluminium face width	74.7 mm
Frame height	58.6 mm
Frame width	37 / 42 mm
Sash height	56 mm
Sash width	44 mm
Sash weight	Up to 80 Kg
Glazing	from 10 up to 20 mm
Shades & Colors	100+ shade customization

Alumil Comfort M940 is cost effective & lightweight non insulated system for tilt & turn casements without compromising on performances. Available in a variety of construction solutions.

- / Basic System Depth 37mm.
- / Water & airtightness is achieved through 3 layers of EPDM Gaskets.
- / Great diversity of designs for windows & doors.
- / Can be used in multiple typologies and narrow spans and cost effective projects.
- / System is compatible with European groove mechanism
- / Can be combined with sliding system COMFORT M900.





SMARTIA M9800 is ALUMIL's low-cost solution for high-quality folding doors. It is the non-thermal insulating version of M19800. The series offers two sash options, the standard and the minimal one, with visible face width of 143 mm & 87 mm correspondingly.

#### TECHNICAL CHARACTERISTICS

Visible aluminum face width	143 & 87 mm
Max panel width	1.0 m
Max. height	2.5 m
Sash width	50 mm
Sash weight	Up to 80 Kg. per vent
Glazing	from 26 mm
Shades & Colors	100+ shade customization

- / Basic system's depth 45 mm.
- / Maximum visibility and natural light
- / Exceptional wind load resistance performance, certified under extreme conditions.
- / Flexible constructions of Fold & Slide and regular sliding doors with the same design.
- / Easy use of wide and heavy sashes by Sliding & Folding mechanism. Smooth and easy movement.





ALUMIL's sliding thermally insulated system SUPREME S650 PHOS is the ideal solution for projects requiring wide spans with minimal aluminum site lines. Massive, yet elegant, glazing surfaces are achieved, while maintaining high functionality, performance and minimal architectural design. The system's main advantage is the improvement of living conditions, by maximizing the natural light & minimizing the visible aluminium face width. Thus, the residents feel closer to external environment, increasing their sense of freedom

- / Basic system's depth 62 mm.
- / Profiles are totally integrated into the walls, maximizing natural light in the buildings.
- / Only 25 mm visible aluminum face width at the interlocking profile.
- / SS rollers for smooth sliding & maximum functionality, with high resistance to corrosion.
- / Availability of 3 alternative solutions for on-floor, in-floor or totally concealed in-floor installation, covered with floor finish.



## TECHNICAL CHARACTERISTICS

Visible aluminium face width	Concealed profiles
Frame height	35 / 59 mm
Frame height	164 mm
Sash height	22 / 32 mm
Sash width	62 mm
Interlocking profile width	25 mm
Sash weight Up to	Up to 1000 Kg
Glazing	35 / 45 mm
Thermal insulation	Polyamides, PVC
Shades & Colors	100+ shade customization



# ALUMINIUM DOMAL SECTION SERIES



In Glassco we also provides Domal saction windows of Jindal solutions which provides you a good quality aluminum solutions with a wide range of product categories and affordable solutions like, Casement windows, sliding windows, 'Z' section, windows ventilation and many more at pocket friendly budget.

## GDJ-10

## Casement Series



Our Domal Section Casement windows are best for the Tight budget oriented projects, Ideal for running use, better choice in medium segment windows. This series can also be used for small openings in bedrooms, common areas and other places like ventilation.

## GDJ-20

## Sliding Series



The versatility of this series is ideal for running use It offers better quality of Jindal system & a wide range of locking solutions Keeping in line with the current requirement of the market, windows are becoming an integral part of the elevation, this series is designed to merge better function with budget friendly and relatively low cost.



**QUALITY  
GUARANTEED**

## Terms

- Taxes will be charged extra at actual.
- Product Shown in Catalogue are the visual & may be differ from original,
- Visual & printed colors which indicates the shades are not 100% match to real ones
- All products are provide according to the availability & current factors basis.
- Order delivered in specific time given by company due to manufacturing & processing time.
  - Call on customer help line number for maintenance issues,
    - service will be provided asper circumstances.
  - Payment should be done as per company's decided payment terms only.
    - All subject to Anand Jurisdiction only.



Advance Technology



Safe & Strong



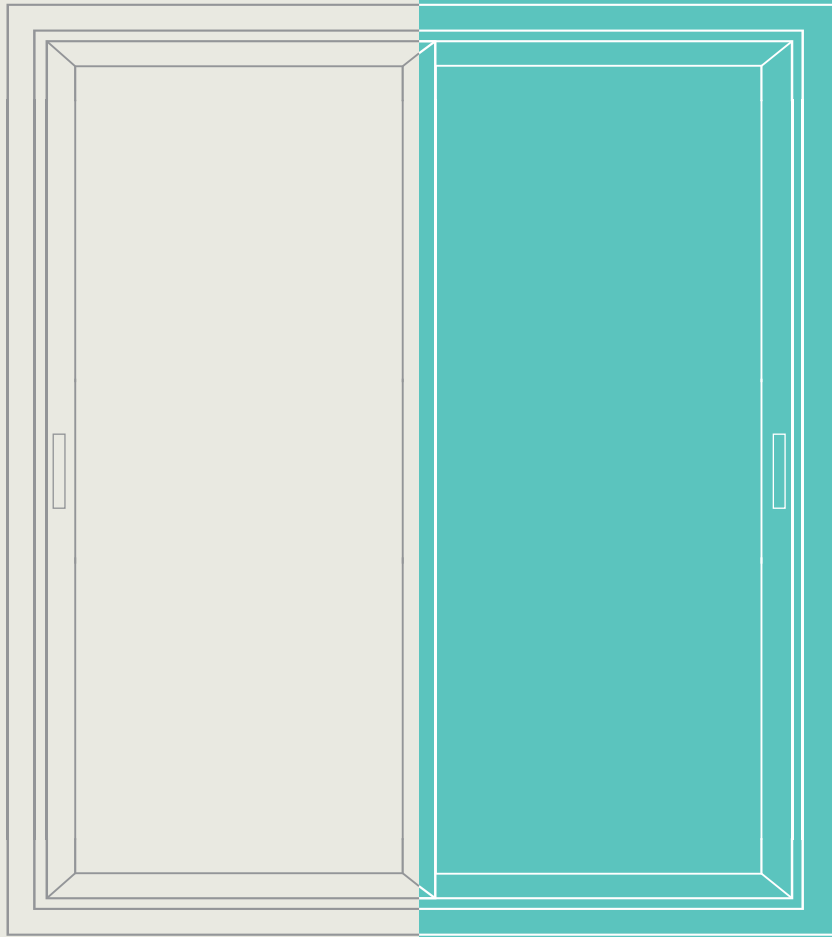

Specifications subject to  
change without update as per situations



Marketed & Mfg. by :

Glassco Solutions,  **Glassco**<sup>®</sup>  
Opp. Rajshivalaya cinema, nr. Geeta Glass,  
Mogri Road, Anand, Gujrat, 388 001

 +91-9825446914 / +91-9998956914

 [info@glassco.co.in](mailto:info@glassco.co.in)

 [www.glassco.co.in](http://www.glassco.co.in)

Join us on,



**GG**  
Group

